

IR SENS^{LITE} SERIES

Model No.: SZ-LITE-N₂O-1000 PPM

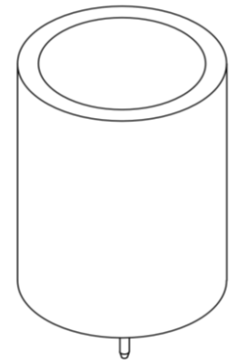

ISOMETRIC VIEW

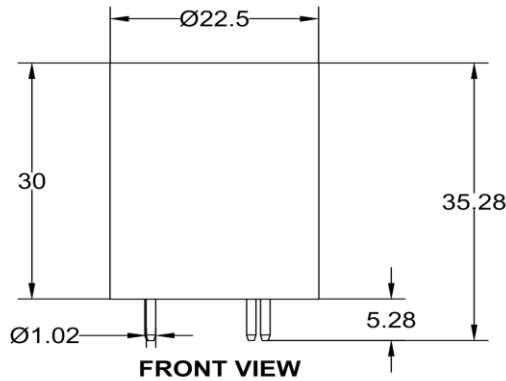
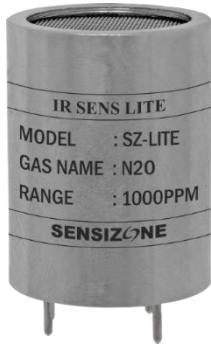
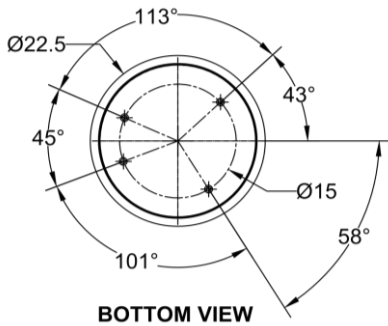

BOTTOM VIEW

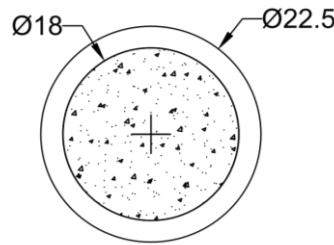

TOP VIEW

Gas Analysis the Smarter way... High Precision & Durable Sensors.....

We are highly Focused on Customized Solution & Maintaining the highest quality standards with exceptional customer service

IR SENS^{LITE}

- Infrared Gas Sensor Nitrous oxide N₂O :1000 PPM
- Pre Calibrated & Low drift
- Compact Design
- 3.3 VCC Supply Voltage
- Sensor Life > 5 Years
- Gas Entry by diffusion
- TTL Output

FEATURES :

Measuring Principle	: Non – Dispersive Infra-Red
Measurement Range	: 0 – 1000 PPM Full Scale
Flow Rate (Calibration)	: 0.5 - 0.8 LPM
Warm-up time	: 60 sec.
Accuracy	: 5% of Reading or ±20 PPM Whichever is More

SPECIFICATIONS :

Digital Resolution	: 1 PPM
Response Time	: < 6 Sec. @ 0.5 LPM
T90 (10 to 90 % FS)	: < 45 Sec. @ 0.5 LPM
Repeatability	: ± 10 PPM
Linearity Error	: ± 10 PPM
Long term stability	: ≤ ± 0.5% Vol. Over 12 month period
Weight	: 42.2 Grams

ELECTRICAL SPECIFICATION :

Supply Voltage	: 3.2 VCC to 3.6 VCC
Supply Current (peak)	: 80 mA @ 3.3 VDC
Digital Output Signal	: MODBus Protocol TTL UART @9600,8,1,N
Calibration	: Zero and span

ENVIRONMENTAL CONDITIONS :

Operating Temperature	: -10 to +50°C
Storage Temperature	: -20 to +60°C
Air Pressure	: 800 to 1150 hPa
Ambient Humidity	: 0-95 % Relative Humidity (Not Condensing)

TEMPERATURE PRESSURE EFFECTS:

Temp. Dependence (Zero)	: $\leq \pm 10$ PPM per °C
Temp. Dependence (Span)	: $\leq \pm 20$ PPM per °C
Method of Detection	: Diffusion

SOME TYPICAL APPLICATIONS:

- Semiconductor Industry
- Food Industry
- Medical

LIST OF NDIR BASED GAS WITH ENVIRONMENTAL CONDITION

Sr. No.	MODEL NO.	GAS NAME	GAS FORMULA	GAS RANGE	RESOLUTION	ACCURACY	REPEATABILITY	LINEARITY ERROR	T90
1	SZ-LITE-N2O-1000	Nitrous oxide	N ₂ O	1000 PPM or more	1 PPM	< 5 % of Reading or ± 20 PPM Whichever is More	± 10 PPM	± 10 PPM	< 45 sec.
2	SZ-LITE-CO-10%	Carbon monoxide	CO	10%V/V	0.01%V/V	< 3% of Reading or $\pm 0.2\%$ V/V Whichever is More	$\pm 0.2\%$ V/V	$\pm 0.1\%$ V/V	< 30 sec.
3	SZ-LITE-CO2-5000	Carbon dioxide	CO ₂	5000 PPM	1 PPM	< 5% of Reading or ± 50 PPM Whichever is More	± 100 PPM	± 50 PPM	< 45 sec.
4	SZ-LITE-CO2-10000	Carbon dioxide	CO ₂	10000 PPM	1 PPM	< 5% of Reading or ± 30 PPM Whichever is More	± 20 PPM	± 30 PPM	< 45 sec.
5	SZ-LITE-CO2-5%	Carbon dioxide	CO ₂	5% V/V	0.01% V/V	< 5% of Reading or $\pm 0.5\%$ V/V Whichever is More	$\pm 0.02\%$ V/V	$\pm 0.1\%$ V/V	< 30 sec.
6	SZ-LITE-CO2-100%	Carbon dioxide	CO ₂	100% V/V	0.1% V/V	< 2 % of Reading or $\pm 0.5\%$ V/V Whichever is More	$\pm 1\%$ V/V	$\pm 2\%$ V/V	< 30 sec.
7	SZ-LITE-CH4-100%	Methane	CH ₄	100 % LEL	0.1% LEL	< 5 % of Reading or $\pm 0.5\%$ LEL Whichever is More	$\pm 2\%$ LEL	$\pm 2\%$ LEL	< 30 sec.
8	SZ-LITE-CH4-100%	Methane	CH ₄	100% V/V	0.1% V/V	< 5% of Reading or $\pm 0.5\%$ V/V Whichever is More	$\pm 2\%$ V/V	$\pm 2\%$ V/V	< 30 sec.
9	SZ-LITE-HC-100%	Hydrocarbon	HC	100 % LEL	0.1% LEL	< 5% of Reading or $\pm 0.5\%$ LEL Whichever is More	$\pm 2\%$ LEL	$\pm 2\%$ LEL	<30 sec.
10	SZ-LITE-R134a-1000	Refrigerant	R134a	1000 PPM or more	1 PPM	< 5% of Reading or ± 30 PPM Whichever is More	± 20 PPM	± 30 PPM	<60 sec.
11	SZ-LITE-SF6-1000	Sulphur hexafluoride	SF ₆	1000 PPM or more	1 PPM	< 5% of Reading or ± 30 PPM Whichever is More	± 20 PPM	± 30 PPM	<60 sec.

***For other gases, please contact our sales team**