

## IR SENS<sup>LITE</sup> SERIES

Model No.: SZ-LITE-HC-100%LEL

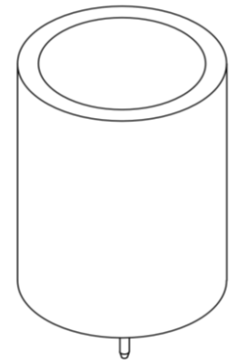

ISOMETRIC VIEW

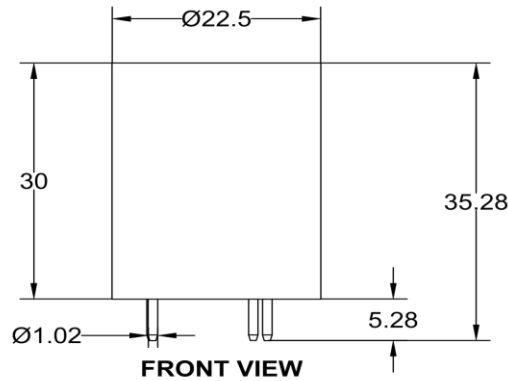
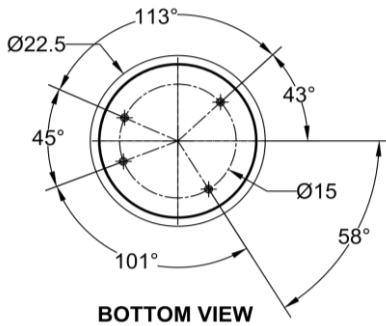

BOTTOM VIEW

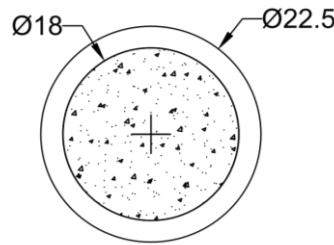

TOP VIEW

## Gas Analysis the Smarter way... High Precision & Durable Sensors.....

We are highly Focused on Customized Solution & Maintaining the highest quality standards with exceptional customer service

## IR SENS<sup>LITE</sup>

- Infrared Gas Sensor Hydrocarbon HC :100% LEL
- Pre Calibrated & Low drift
- Compact Design
- 3.3 VCC Supply Voltage
- Sensor Life > 5 Years
- Gas Entry by diffusion
- TTL Output

## FEATURES :

<b>Measuring Principle</b>	: Non – Dispersive Infra-Red
<b>Measurement Range</b>	: 0 – 100% LEL Full Scale
<b>Flow Rate (Calibration)</b>	: 0.5 - 0.8 LPM
<b>Warm-up time</b>	: 60 sec.
<b>Accuracy</b>	: < 5% of Reading or ±0.5% LEL Whichever is More

## SPECIFICATIONS :

<b>Digital Resolution</b>	: 0.1% LEL
<b>Response Time</b>	: < 6 Sec. @ 0.5 LPM
<b>T90 (10 to 90% FS)</b>	: < 30 Sec. @ 0.5 LPM
<b>Repeatability</b>	: ± 2% LEL
<b>Linearity Error</b>	: ± 2% LEL
<b>Long term stability</b>	: ≤ ± 0.5% LEL Over 12 month period
<b>Weight</b>	: 42.2 Grams

## ELECTRICAL SPECIFICATION :

Supply Voltage	: 3.2 VCC to 3.6 VCC
Supply Current (peak)	: 80 mA @ 3.3 VDC
Digital Output Signal	: MODBus Protocol TTL UART @9600,8,1,N
Calibration	: Zero and span

## ENVIRONMENTAL CONDITIONS :

Operating Temperature	: -10 to +50°C
Storage Temperature	: -20 to +60°C
Air Pressure	: 800 to 1150 hPa
Ambient Humidity	: 0-95% Relative Humidity (Not Condensing)

## TEMPERATURE PRESSURE EFFECTS:

Temp. Dependence (Zero)	: $\leq \pm 0.1\%$ LEL per °C
Temp. Dependence (Span)	: $\leq \pm 0.2\%$ LEL per °C
Method of Detection	: Diffusion

## SOME TYPICAL APPLICATIONS:

- Refineries
- Cold Storage
- Sewage Plants
- Industrial Processes

## LIST OF NDIR BASED GAS WITH ENVIRONMENTAL CONDITION

Sr. No.	MODEL NO.	GAS NAME	GAS FORMULA	GAS RANGE	RESOLUTION	ACCURACY	REPEATABILITY	LINEARITY ERROR	T90
1	SZ-LITE-N2O-1000	Nitrous oxide	N <sub>2</sub> O	1000 PPM or more	1 PPM	< 5 % of Reading or $\pm 20$ PPM Whichever is More	$\pm 10$ PPM	$\pm 10$ PPM	< 45 sec.
2	SZ-LITE-CO-10%	Carbon monoxide	CO	10%V/V	0.01%V/V	< 3% of Reading or $\pm 0.2\%$ V/V Whichever is More	$\pm 0.2\%$ V/V	$\pm 0.1\%$ V/V	< 30 sec.
3	SZ-LITE-CO2-5000	Carbon dioxide	CO <sub>2</sub>	5000 PPM	1 PPM	< 5% of Reading or $\pm 50$ PPM Whichever is More	$\pm 100$ PPM	$\pm 50$ PPM	< 45 sec.
4	SZ-LITE-CO2-10000	Carbon dioxide	CO <sub>2</sub>	10000 PPM	1 PPM	< 5% of Reading or $\pm 30$ PPM Whichever is More	$\pm 20$ PPM	$\pm 30$ PPM	< 45 sec.
5	SZ-LITE-CO2-5%	Carbon dioxide	CO <sub>2</sub>	5% V/V	0.01% V/V	< 5% of Reading or $\pm 0.5\%$ V/V Whichever is More	$\pm 0.02\%$ V/V	$\pm 0.1\%$ V/V	< 30 sec.
6	SZ-LITE-CO2-100%	Carbon dioxide	CO <sub>2</sub>	100% V/V	0.1% V/V	< 2 % of Reading or $\pm 0.5\%$ V/V Whichever is More	$\pm 1\%$ V/V	$\pm 2\%$ V/V	< 30 sec.
7	SZ-LITE-CH4-100%	Methane	CH <sub>4</sub>	100 % LEL	0.1% LEL	< 5 % of Reading or $\pm 0.5\%$ LEL Whichever is More	$\pm 2\%$ LEL	$\pm 2\%$ LEL	< 30 sec.
8	SZ-LITE-CH4-100%	Methane	CH <sub>4</sub>	100% V/V	0.1% V/V	< 5% of Reading or $\pm 0.5\%$ V/V Whichever is More	$\pm 2\%$ V/V	$\pm 2\%$ V/V	< 30 sec.
9	SZ-LITE-HC-100%	Hydrocarbon	HC	100 % LEL	0.1% LEL	< 5% of Reading or $\pm 0.5\%$ LEL Whichever is More	$\pm 2\%$ LEL	$\pm 2\%$ LEL	<30 sec.
10	SZ-LITE-R134a-1000	Refrigerant	R134a	1000 PPM or more	1 PPM	< 5% of Reading or $\pm 30$ PPM Whichever is More	$\pm 20$ PPM	$\pm 30$ PPM	<60 sec.
11	SZ-LITE-SF6-1000	Sulphur hexafluoride	SF <sub>6</sub>	1000 PPM or more	1 PPM	< 5% of Reading or $\pm 30$ PPM Whichever is More	$\pm 20$ PPM	$\pm 30$ PPM	<60 sec.

\*For other gases, please contact our sales team